

Winding Ohmmeter **RMO-TW**

- Three resistance measurement channels
- One temperature measurement channel
- Accuracy 0,1 %
- Lightweight
- On-load tap changer verification
- Automatic resistance measurement for the Heat Run test
- Automatic discharge circuit
- Four models: RMO10TW, RMO20TW, RMO30TW, RMO50TW



Description

The Winding Ohmmeter of the RMO-TW series is designed for winding resistance measurement of inductive objects. The RMO-TW instrument is based on the state of the art technology, using the most advanced switch mode technology available today. The RMO-TW instrument is accurate (0,1%), powerful (up to 50 A) and lightweight. It generates a true DC ripple free current with automatically regulated measurement and discharging circuit.

RMO-TW instrument can perform a simple, quick and reliable transformer on-load tap changer verification. This instrument enables measurements of a winding resistance in every tap position of an on-load tap changer without discharging between the tests. Problems with switching of the OLTC, such as interruption, can be detected with these measurements.

Application

The list of the instrument application includes:

- Three-channel winding resistance measurement, which enables simultaneous winding resistance measurement of up to three windings on a single phase
- Detection of interruptions during the operation of on-load tap changers (OLTC), performed on a single phase
- Heat Run test, which enables obtaining the Hot Spot temperature along with resistance graph during the cooling process

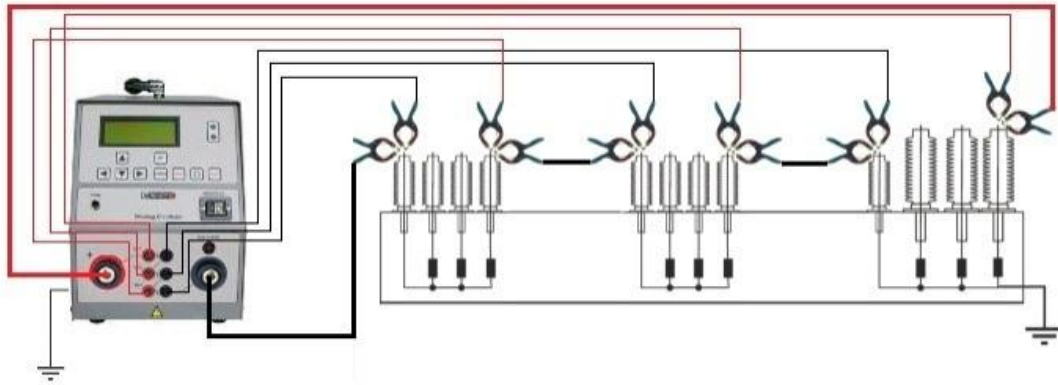

Connecting RMO-TW to Transformer

The RMO-TW has three separate resistance measurement channels, which enable simultaneous measurement of the primary, secondary and tertiary winding on the same phase, as presented in the figure above. This significantly speeds up the measurement and reduces the total transformer testing time. At the same time, by saturating the magnetic core through the HV and LV windings the stabilization time and subsequently the total testing time is reduced even more.

Simultaneous Three-Channel Winding Resistance Measurement

The RMO-TW injects the current with a voltage value as high as 55 V. This ensures that the magnetic core is saturated quickly and duration of the test is as short as possible. The three independent channels enable simultaneous testing of three windings in series – primary, secondary and tertiary windings. There is enough memory within the RMO-TW instrument to store 1 000 measurements. All measurements are time and date stamped.

The instrument is equipped with thermal and overcurrent protection. The RMO-TW has very high ability to cancel electrostatic and electromagnetic interference that exists in HV electric fields. It is achieved by a proprietary filtration solution applied to both, the hardware construction and the application software implementation. A special mode is provided for the resistance measurement in multiple de-energized tap changer (DETC) positions.

Resistance Testing in Multiple Tap Changer Positions

The winding resistance of all tap changer positions in one phase can be measured as part of a single test, without discharging between measurements. Different test modes are provided for on-load tap changers (OLTC) and de-energized tap changers (DETC). The instrument detects interruptions during the operation of on-load tap changers and produces a warning message to the operator.

DV-Win Software

The DV-Win application software enables control and observation of the test process, as well as saving and analyzing the results on a PC. It provides a test report, arranged in a selectable form as an Excel spreadsheet, PDF, Word, or ASCII format. The software provides additional OLTC (tap changer) verification option by recording the test current during the transition. The standard interface is USB. RS232 is optional.

Heat Run Test Application

The DV-Win application software has an additional Heat Run temperature/resistance extrapolation feature. After the transformer heating is switched off, the RMO-TW is immediately connected to up to three transformer windings and the timer is started. The winding resistance is measured at regular time intervals. This information is used to automatically extrapolate the values of temperature and resistance at the moment when the transformer was switched off.

Technical Data

Winding Resistance Measurement

- Test currents:
 - 5 mA – 10 A DC for RMO10TW
 - 5 mA – 20 A DC for RMO20TW
 - 5 mA – 30 A DC for RMO30TW
 - 5 mA – 50 A DC for RMO50TW
- Output voltage: up to 55 V DC
- Measurement range: 0,1 $\mu\Omega$ - 10 k Ω
- Typical accuracy:
 - $\pm(0,1\% \text{ rdg} + 0,1\% \text{ F.S.})$ for 0,1 $\mu\Omega$ -1,999 k Ω range
 - $\pm(0,2\% \text{ rdg} + 0,1\% \text{ F.S.})$ for 2 k Ω - 10 k Ω range

Resolution

- 0,1 $\mu\Omega$ – 999,9 $\mu\Omega$: 0,1 $\mu\Omega$
- 1,000 m Ω – 9,999 m Ω : 1 $\mu\Omega$
- 10,00 m Ω – 99,99 m Ω : 10 $\mu\Omega$
- 100,0 m Ω – 999,9 m Ω : 0,1 m Ω
- 1,000 Ω – 9,999 Ω : 1 m Ω
- 10,00 Ω - 99,99 Ω : 10 m Ω
- 100,0 Ω – 999,9 Ω : 0,1 Ω
- 1,000 k Ω – 9,999 k Ω : 1 Ω

Data Storage

- 1 000 internal memory positions

Printer (optional)

- Thermal printer
- Paper width 80 mm

OLTC Dynamic Resistance Measurement

- Sampling rate: 4 ms
- Automatic open circuit detection and warning
- Transition current ripple measurement
- Transition time measurement using DV-Win software
- Timing measurement of different transition changes using DV-Win graph analysis tool

Computer Interface

- USB
- Optional: RS232

Warranty

- Three years

Environmental Conditions

- Operating temperature:
 - 10 $^{\circ}\text{C}$ to +55 $^{\circ}\text{C}$ / + 14 $^{\circ}\text{F}$ to + 131 $^{\circ}\text{F}$
- Storage & transportation:
 - 40 $^{\circ}\text{C}$ to +70 $^{\circ}\text{C}$ / - 40 $^{\circ}\text{F}$ to + 158 $^{\circ}\text{F}$
- Humidity 5 % - 95 % relative humidity, non condensing

Dimensions and Weight

Device	Weight	Dimensions (WxHxD)
RMO10TW RMO20TW	7.5 kg / 16.5 lbs	198 x 255 x 380 mm 7.8 x 10.0 x 15.0 in
RMO30TW RMO50TW	8.5 kg / 18.7 lbs	198 x 255 x 380 mm 7.8 x 10.0 x 15.0 in

Mains Power Supply

- Connection according to IEC/EN60320-1; UL498, CSA 22.2
- Mains supply: 90 V - 264 V AC
- Frequency: 50 / 60 Hz
- Mains supply voltage fluctuations up to $\pm 10\%$ of the nominal voltage
- Input power: 2 250 VA
- Fuse 15 A / 250 V, type F, not user replaceable

Applicable Standards

- Installation/overvoltage: category II
- Pollution: degree 2
- Low voltage directive: Directive 2014/35/EU (CE conform); Applicable standards, for a class I instrument, pollution degree 2, installation category II: IEC EN61010-1
- EMC: Directive 2014/30/EU (CE Conform)
Applicable standard EN 61326-1
- Safety: CAN/CSA-C22.2 No. 61010-1, 2nd edition, including Amendment 1

All specifications herein are valid at ambient temperature of + 25 $^{\circ}\text{C}$ and recommended accessories.
Specifications are subject to change without notice.
Specifications are valid if the instrument is used with the recommended set of accessories.



Current and Sense cables with TTA clamps



Voltage Sense cables with TTA clamps



Device bag



Cable plastic case



Current connection cable with TTA clamps



Cable bag



Transport case



Test shunt

Order Info

Instrument with Included accessories	Article No
Winding Ohmmeter RMO-TW	RMOXXTW-N-00
DV-Win PC software including USB cable	
Mains Power cable	
Ground (PE) cable	

Recommended	Article No
Current cables 2 x 10 m 10 mm ² (32.8 ft, 7 AWG) and Sense cables 2 x 10 m (32.8 ft) with TTA clamps*	CS-10-10LMWC
Current cables 2 x 10 m 2,5 mm ² (32.8 ft, 13 AWG) and Sense cables 2 x 10 m (32.8 ft) with TTA clamps**	CS-10-02BPWC
Sense cables 2 x 2 x 10 m (32.8 ft) with TTA clamps	S2-10-02BPWC
Current connection cable 2 x 1 x 5 m 10 mm ² (16.4 ft, 7 AWG) with TTA clamps*	CX-05-102XWC
Current connection cable 2 x 1 x 5 m 6 mm ² (16.4 ft, 9 AWG) with TTA clamps**	CX-05-062XWC
Transport case	HARD-CASE-ME

*Recommended for RMO30TW and RMO50TW

** Recommended for RMO10TW and RMO20TW

Optional	Article No
Test shunt 150 A / 150 mV	SHUNT-150-MK
Thermal printer 80 mm (3.15 in) (built-in)	PRINT-080-00
Cable plastic case – small size	CABLE-CAS-01
Cable plastic case – medium size	CABLE-CAS-02
Cable bag	CABLE-BAG-00
Current cables 2 x 15 m 10 mm ² (49.2 ft, 7 AWG) and Sense cables 2 x 15 m (49.2 ft) with TTA clamps	CS-15-10LMXC
Current cables 2 x 15 m 2,5 mm ² (49.2 ft, 13 AWG) and Sense cables 2 x 15 m (49.2 ft) with TTA clamps	CS-15-02BPWC
Current cables 2 x 20 m 16 mm ² (65.6 ft, 5 AWG) and Sense cables 2 x 20 m (65.6 ft) with TTA clamps	CS-20-10LMXC
Current cables 2 x 20 m 2,5 mm ² (65.6 ft, 13 AWG) and Sense cables 2 x 20 m (65.6 ft) with TTA clamps	CS-20-02BPWC
Sense cables 2 x 15 m (49.2 ft) with TTA clamps	S2-15-02BPWC
Sense cables 2 x 20 m (65.6 ft) with TTA clamps	S2-20-02BPWC
Current connection cable 1 x 12 m 10 mm ² (39.4 ft, 5 AWG) with TTA clamps	CX-12-102XWC
Current connection cable 1 x 12m 6 mm ² (39.4.4 ft, 9 AWG) with TTA clamps	CX-12-062XWC

IBEKO Power AB

Stockholmsvägen 18
181 50 Lidingö, Sweden

Contact

Phone: +46 70 0925 000
E-mail: sales@dv-power.com